

Functional Description

The ultrasonic sensor is a solid-state proximity type switch for 24 VDC, which uses the echo delay time method for distance sensing. It senses a sound-reflecting object, which enters the sound cone from any direction. The objects to be sensed can be solid, liquid or powdery.

Installation

Figure I (dimensions in mm)
Mounting position: any
Keep free space around the sound cone of a distance "x" (= 60 mm) from reflecting objects (Figure II)

Connection

By means of cable socket (Figure III) part no. 237-13442-4 (included in the scope of delivery)

Pin		
1	L+	DC 20...30 V
2	S1	Switching output "High level" (NO)
3	L-	Ground (GND)
4	S2	Switching output "Low level" (NC)

The connections are polarized, short-circuit proof and overload-proof. In the case of electrical faults we recommend to use shielded lines.

Switching Range (Figure IV)

a	Unusable blind zone
b	Sensing range
c	Overflow range
HV	Hysteresis high level
HL	Hysteresis low level

The objects are sensed reliably in the set switching range within an opening angle of the sound cone of approx. 5°. If the reflecting conditions are good, the objects can also be sensed outside the sound cone.

Keep the blind zone "a" free from objects. These would cause undefined switching states.

Take care that the surface of the transducer is clean!

Display:

Reservoir empty:	H2 is lit
Filling level O.K.	H2 is not lit
Reservoir full	H1 is lit
Supply voltage:	H3 is lit: green
Overflow signal:	H3 is lit: red

Part Numbers

Ultrasonic sensor adjusted for reservoir: Part no.:

4L (pump 205)	664-36939-1
5L (pump 205)	664-36939-2
8L (pump 205)	664-36939-3
10L (pump 215)	664-36939-4
30L (pump 215)	664-36939-5
100L (pump ZPU 08/14/24)	664-34009-3

Special Accessories

Cable socket with 5 m cable, part no. 237-13429-6*

Cable socket with 10 m cable, part no. 236-10022-7*

Interlock protection for EX-area 237-10254-1

* in combination with interlock protection also applicable in the EX-area

Technical Data

Ambient temperature	- 25...70°C
Sensing range	50...500 mm *
Sensing distance "high level" S1	60 mm *
Sensing distance "low level" S2	depends on the reservoir size
Hysteresis "high level" HV	20 mm
Hysteresis "low level" HL	50 mm
Switching point default	0.17% / K
<i>*measured on the housing surface</i>	

Supply:

Rated operational voltage	U _E	24 VDC
Operating voltage range	U _B	20...30 VDC
Admissible residual ripple		10 %
Open-circuit		< 60 mA

Switching Output:

Rated normal current	I _e	≤ 200 mA
Voltage drop	U _d	≤ 3 V
Spurious switch-on pulse		suppressed
Switching function "high level":		NO contact, switching on "plus"
"low level"		NC contact; switching on "plus"

Typical Values:

Availability delay		250 ms
Reflection area		10 x 10 mm ²
Ultrasonic frequency		400 kHz
Switching frequency		8 Hz
Resolution		1 mm
Protection		IP 65

Relevant Data for EX- Protection:

The accordance with directive 94/9/EEC (ATEX) is proved by the compliance with the standards EN 50021, EN 50281-1-1 and EN 60947-5-2

Appropriate Use

Application in areas subject to explosion hazards
Zone 2 according to classification II 3G (gas atmosphere)
Zone 22 according to classification II 3D (dust atmosphere)

Special conditions for safe operation:

- Protect the environment of the push-in type connection against mechanical damages.
- Secure the push-in type connection with an interlock protection (part no. 237-10254-1) to make a separation by hand impossible.
- Protect plug against dust or water when unpacking.

Installation and start-up

- The admissible ambient temperature for the devices is - 20°C to +70°C.
- Installation, connection and start-up of the devices must be carried out by authorized and qualified personnel.
- The installation requires knowledge regarding the assignment of classifications to the allowed areas subject to explosion hazards.
- The push-in type connection must not be connected or separated when voltage is applied.

Maintenance and Troubleshooting

- The devices do not require maintenance.
- The devices must not be modified at all.
- Repairs of the devices are not possible.
- In the case of replacement consider the above points.

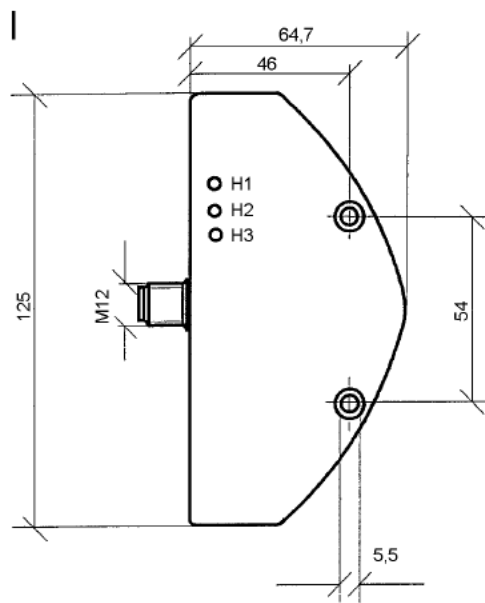

30 mm high

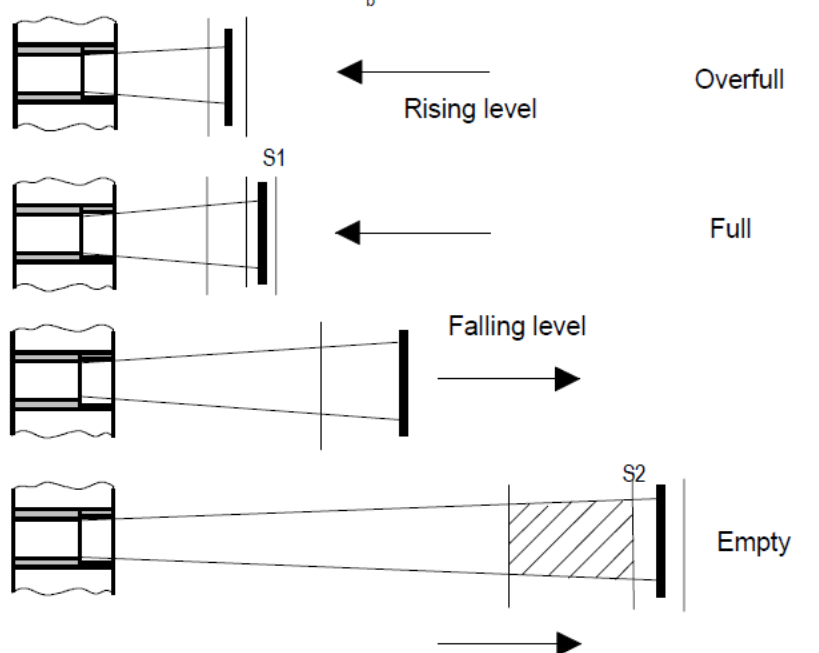
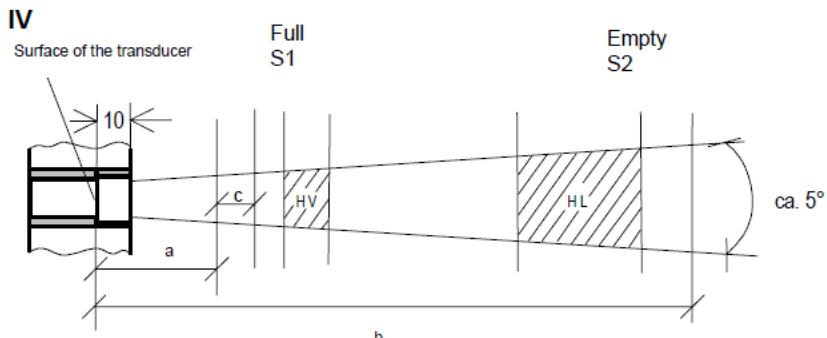
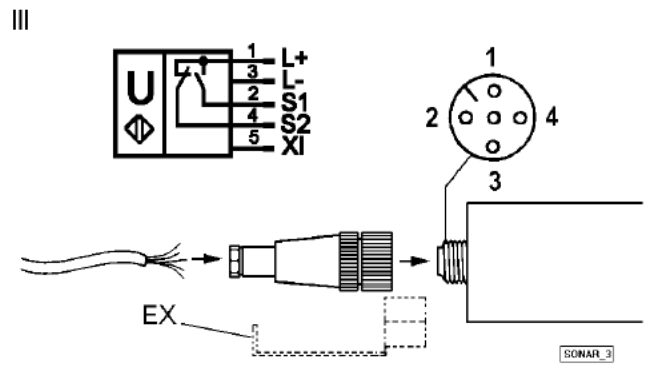
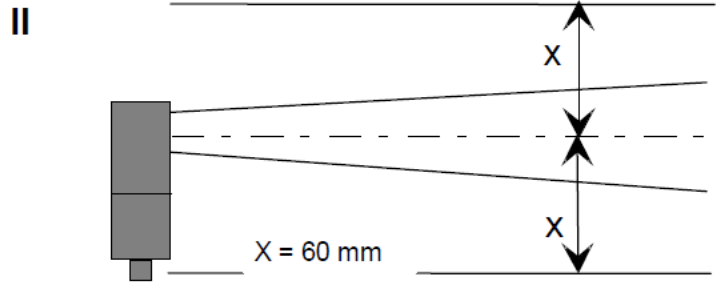

	Full	Empty	
Overfull	S1	S2	
	1	1	
	H1	H2	H3
	on	off	red
Full	S1	S2	
	1	1	
	H1	H2	H3
	on	off	green
Falling level	S1	S2	
	0	1	
	H1	H2	H3
	off	off	green
Empty	S1	S2	
	0	0	
	H1	H2	H3
	off	on	green